

# LEDsplash™ 152B

## Snapshot

Use on Dimmer	⊘
Outdoor Use	⊘
Sound Activated	✓
DMX	✓
Master/Slave	✓
115V/230V Switch	✓
Replaceable Fuse	✓
User Serviceable	⊘
Duty Cycle	⊘

## User Manual

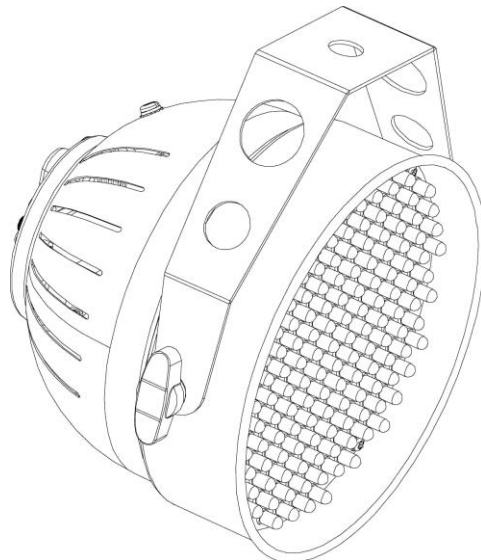

# TABLE OF CONTENTS

<b>1. Before You Begin</b> .....	<b>3</b>
What is included.....	3
Unpacking Instructions.....	3
AC Power.....	3
Contact Us.....	3
Safety Instructions.....	4
<b>2. Introduction</b> .....	<b>5</b>
Features.....	5
DMX Channel Summary.....	5
Product Overview.....	6
Product Dimensions.....	6
<b>3. Setup</b> .....	<b>8</b>
Fuse Replacement.....	8
Fixture Linking.....	8
Data Cabling.....	8
DMX Data Cable.....	8
Cable Connectors.....	9
3-Pin to 5-Pin Conversion Chart.....	9
Setting up a DMX Serial Data Link.....	9
Master/Slave Fixture Linking.....	10
Mounting.....	10
Orientation.....	10
Rigging.....	10
<b>4. Operating Instructions</b> .....	<b>11</b>
Operation.....	11
Stand-Alone Mode (Sound-Active, Auto Mode):.....	11
Master/Slave Mode (Master Sound, Master Auto):.....	11
Dipswitch Functions.....	11
DMX Mode.....	12
DMX Channel Values.....	12
Setting the DMX starting address.....	13
DMX Quick Reference Chart.....	14
General Troubleshooting.....	15
Technical Support.....	16
<b>5. Appendix</b> .....	<b>16</b>
DMX Primer.....	16
General Maintenance.....	16
Returns Procedure.....	17
Claims.....	17
Technical Specifications.....	18

# 1. BEFORE YOU BEGIN

## What is included

- 1 x LEDsplash™ 152B
- Warranty Card
- User Manual

## Unpacking Instructions

Immediately upon receiving a fixture, carefully unpack the carton, check the contents to ensure that all parts are present, and have been received in good condition. Notify the shipper immediately and retain packing material for inspection if any parts appear damaged from shipping or the carton itself shows signs of mishandling. Save the carton and all packing materials. In the event that a fixture must be returned to the factory, it is important that the fixture be returned in the original factory box and packing.

## AC Power

To determine the power requirements for a particular fixture, see the label affixed to the back plate of the fixture or refer to the fixture's specifications chart. A fixture's listed current rating is its average current draw under normal conditions. All fixtures must be powered directly off a switched circuit and cannot be run off a rheostat (variable resistor) or dimmer circuit, even if the rheostat or dimmer channel is used solely for a 0% to 100% switch. Before applying power to a fixture, check that the source voltage matches the fixture's requirement.

**Warning!** *All fixtures must be connected to circuits with a suitable Earth Ground.*

## Contact Us

### World Wide

**General Information** CHAUVET®  
3000 North 29<sup>th</sup> Court  
Hollywood, FL 33020  
voice: 954.929.1115  
fax: 954.929.5560  
toll free: 800.762.1084

**Technical Support** CHAUVET®  
3000 North 29<sup>th</sup> Court  
Hollywood, FL 33020  
voice: 954.929.1115 **(Press 4)**  
fax: 954.929.5560 **(Attention: Service)**

**World Wide Web** [www.chauvetlighting.com](http://www.chauvetlighting.com)

## Safety Instructions



Please read these instructions carefully, which includes important information about the installation, usage and maintenance of this product.

- Please keep this User Manual for future consultation. If you sell the unit to another user, be sure that they also receive this instruction booklet.
- Always make sure that you are connecting to the proper voltage, and that the line voltage you are connecting to is not higher than that stated on the decal or rear panel of the fixture.
- This product is intended for indoor use only! To prevent risk of fire or shock, do not expose fixture to rain or moisture.
- Make sure there are no flammable materials close to the unit while operating.
- The unit must be installed in a location with adequate ventilation, at least 20 in (50 cm) from adjacent surfaces. Be sure that no ventilation slots are blocked.
- Always disconnect from power source before servicing or replacing lamp or fuse and be sure to replace with same lamp source.
- Secure fixture to fastening device using a safety chain.
- Maximum ambient temperature (Ta) is 104° F (40° C). Do not operate fixture at temperatures higher than this.
- In the event of a serious operating problem, stop using the unit immediately. Never try to repair the unit by yourself. Repairs carried out by unskilled people can lead to damage or malfunction. Please contact the nearest authorized technical assistance center.
- Never connect the device to a dimmer pack.
- Make sure the power cord is never crimped or damaged.
- Never disconnect the power cord by pulling or tugging on the cord.
- Avoid direct eye exposure to the light source while it is on.

### **Caution!**

***There are no user serviceable parts inside the unit. Do not open the housing or attempt any repairs yourself. In the unlikely event your unit may require service, please contact CHAUVET® at: 954-929-1115.***

# 2. INTRODUCTION

## Features

- 6-channel DMX-512 LED wash light
- Blackout/static/dimmer/strobe
- Selector switch for sound active or automatic programs
- Static colors and RGB color mixing with or without DMX controller
- Built-in automated programs via master/slave or DMX
- Built-in sound activated programs via master/slave or DMX

### Additional Features

- Linkable with LED Shadow™, LED Shadow™ 2, LED Techno Strobe™, LED Techno Strobe™ RGB, LEDsplash™ 200B and LEDsplash™ 2 in stand alone

## DMX Channel Summary

1		2	3	4	5	6	DMX CHANNEL (COLUMNS)							
<b>RGB</b>	000~029	Red 000~255	Green 000~255	Blue 000~255	000~020 No Strobe 021~255 Strobe	Dimmer 000~255 100%~0%								
<b>Pulse</b>	030~199 (Slow>Fast)	No Function	No Function	No Function	Strobe 000~255									
<b>Color Macros</b>	120~149	Color Macro 000~255			No Function		No Function	No Function						
<b>RGB Chase</b>	150~179	No Function			No Function		No Function	Chase Speed 000~255 (slow~fast)						
<b>Color Change</b>	180~209							No Function	No Function	No Function	Program Speed 000~255 (slow~fast)			
<b>Color Change w/ fade</b>	210~239										No Function	No Function	No Function	No Function
<b>Sound</b>	240~255													No Function
<b>CONTROL MODES &amp; OPTIONS (Rows)</b>														
For a detailed view of DMX values turn to the Appendix section in this manual. Control mode parameters are set by DMX values in Channel # 1.														

# Product Overview

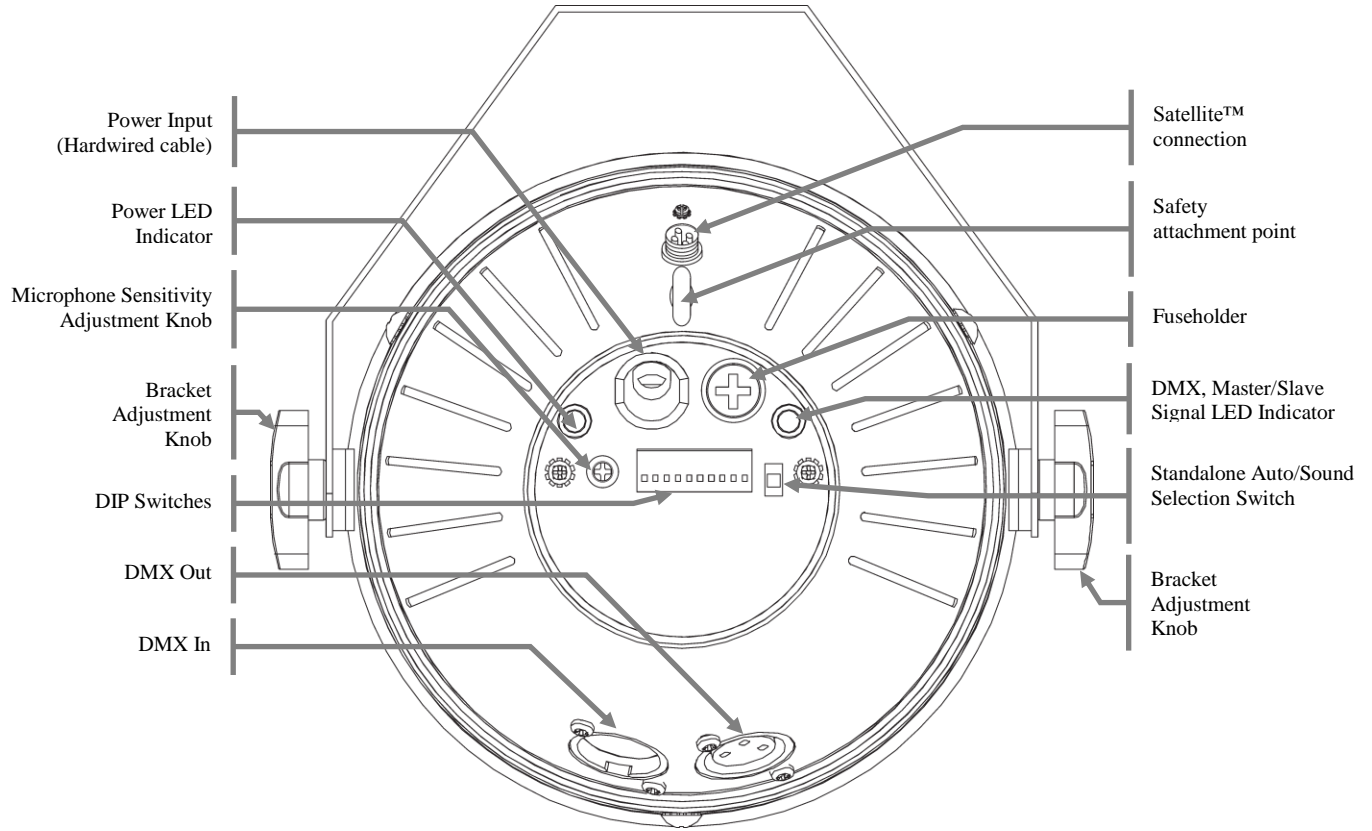

## Product Dimensions

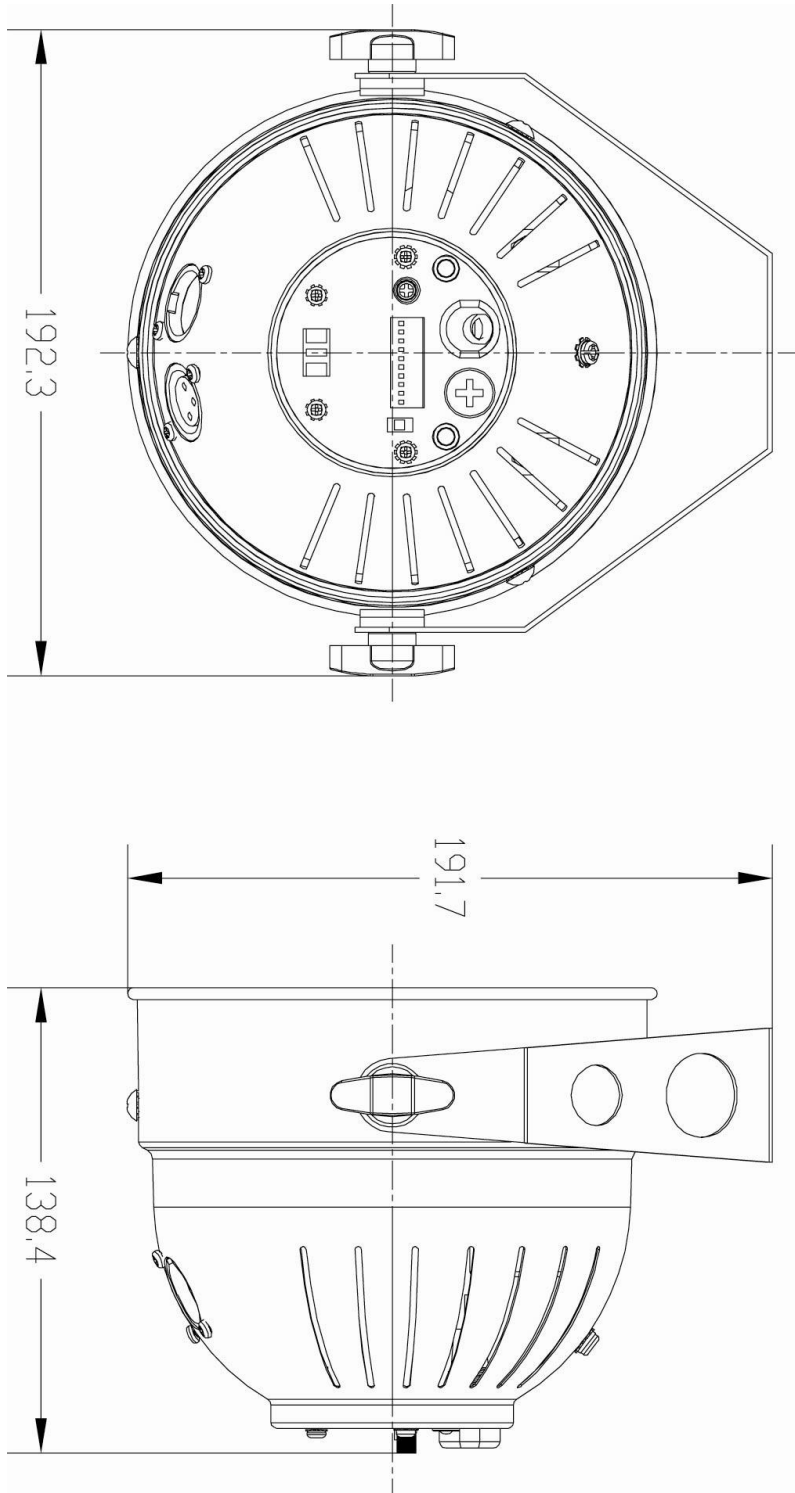

# 3. SETUP



Disconnect the power cord before replacing a fuse, and always replace with the same type fuse.



## Fuse Replacement

With a Phillips #2 screwdriver, unscrew the fuse holder from its housing. Remove the damaged fuse from its holder and replace with exact same type fuse. Screw the fuse holder back in its place and reconnect power.

The fuse is located inside this compartment. Remove using a Phillips #2 screwdriver.



FUSE

## Fixture Linking

You will need a serial data link to run light shows of one or more fixtures using a DMX-512 controller or to run synchronized shows on two or more fixtures set to a master/slave operating mode. The combined number of channels required by all the fixtures on a serial data link determines the number of fixtures the data link can support.

**Important:** Fixtures on a serial data link must be daisy chained in one single line. To comply with the EIA-485 standard no more than 32 devices should be connected on one data link. Connecting more than 32 fixtures on one serial data link without the use of a DMX optically-isolated splitter may result in deterioration of the digital DMX signal.

Maximum recommended serial data link distance: 500 meters (1640 ft.)

Maximum recommended number of fixtures on a serial data link: 32

## Data Cabling

To link fixtures together you must obtain data cables. You can purchase CHAUVET® certified DMX cables directly from a dealer/distributor or construct your own cable. If you choose to create your own cable please use data-grade cables that can carry a high quality signal and are less prone to electromagnetic interference.

## DMX DATA CABLE

Use a Belden© 9841 or equivalent cable which meets the specifications for EIA RS-485 applications. Standard microphone cables cannot transmit DMX data reliably over long distances. The cable will have the following characteristics:

*2-conductor twisted pair plus a shield  
Maximum capacitance between conductors – 30 pF/ft.  
Maximum capacitance between conductor and shield – 55 pF/ft.  
Maximum resistance of 20 ohms / 1000 ft.  
Nominal impedance 100 – 140 ohms*

## CABLE CONNECTORS

Cabling must have a male XLR connector on one end and a female XLR connector on the other end.

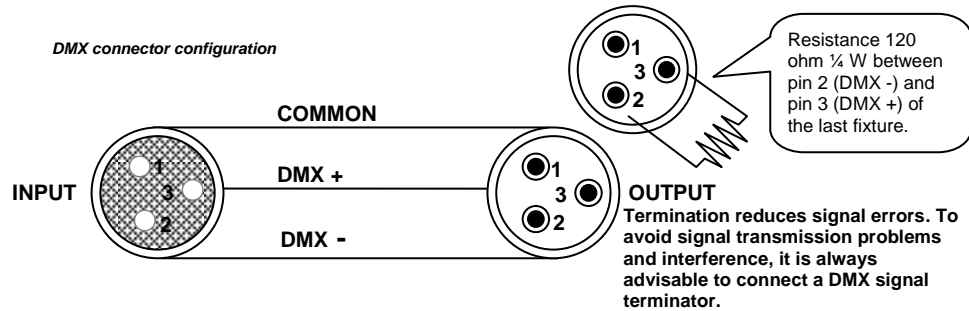

**CAUTION** Do not allow contact between the common and the fixture's chassis ground. Grounding the common can cause a ground loop, and your fixture may perform erratically. Test cables with an ohm meter to verify correct polarity and to make sure the pins are not grounded or shorted to the shield or each other.

## 3-PIN TO 5-PIN CONVERSION CHART

**Note!** If you use a controller with a 5 pin DMX output connector, you will need to use a 5 pin to 3 pin adapter. The chart below details a proper cable conversion:

**3 PIN TO 5 PIN CONVERSION CHART**

Conductor	3 Pin Female (output)	5 Pin Male (Input)
Ground/Shield	Pin 1	Pin 1
Data ( - ) signal	Pin 2	Pin 2
Data ( + ) signal	Pin 3	Pin 3
Not Used		Pin 4
Not Used		Pin 5

## Setting up a DMX Serial Data Link

1. Connect the (male) 3 pin connector side of the DMX cable to the output (female) 3 pin connector of the controller.
2. Connect the end of the cable coming from the controller which will have a (female) 3 pin connector to the input connector of the next fixture consisting of a (male) 3 pin connector.
3. Then, proceed to connect from the output as stated above to the input of the following fixture and so on.

Universal DMX Controller

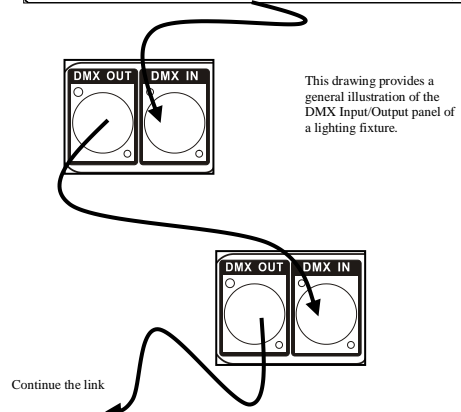
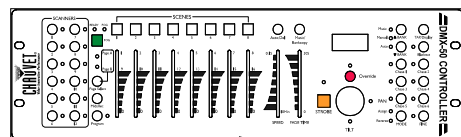

## Master/Slave Fixture Linking

1. Connect the (male) 3 pin connector side of the DMX cable to the output (female) 3 pin connector of the first fixture.
2. Connect the end of the cable coming from the first fixture which will have a (female) 3 pin connector to the input connector of the next fixture consisting of a (male) 3 pin connector. Then, proceed to connect from the output as stated above to the input of the following fixture and so on.

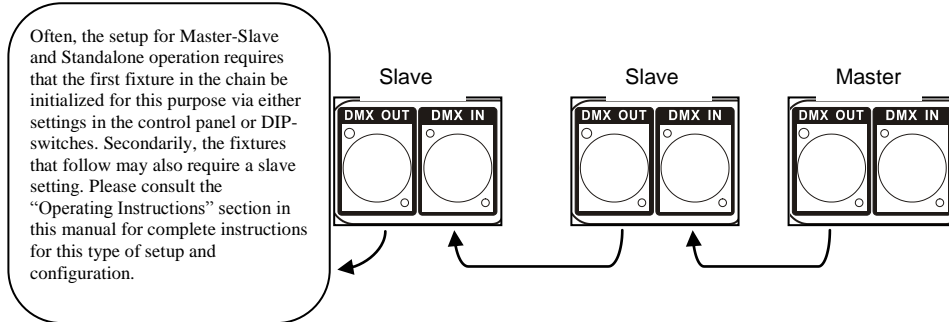

## Mounting

### ORIENTATION

This fixture may be mounted in any safe position, provided there is adequate room for ventilation.

### RIGGING

It is important never to obstruct the fan or vents pathway. Mount the fixture using a suitable "C" or "O" type clamp. Adjust the angle of the fixture by loosening both knobs and tilting the fixture. After finding the desired position, retighten both knobs.

- When selecting installation location, take into consideration lamp replacement access and routine maintenance.
- Safety cables must always be used.
- Never mount in places where the fixture will be exposed to rain, high humidity, extreme temperature changes or restricted ventilation.

*Hanging Clamp*

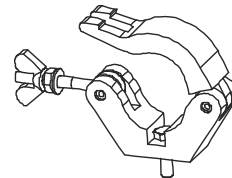

Note!  
Clamp is sold separately.

# 4. OPERATING INSTRUCTIONS

## Operation

### Stand-Alone Mode (Sound-Active, Auto Mode):

This mode allows a single unit to run to the beat of the music, or the unit will auto change in Auto Mode.

- 1) Set dipswitches position to Sound Active or Auto Mode.

Mode	Dipswitches
Sound Active	1-10 = Off, switch set to Music
Auto Mode	1-10 = Off, switch set to Auto

- 2) The unit will react to the low frequencies of music via the internal microphone in Sound Active mode, or the unit will auto change in Auto Mode.
- 3) Use the audio sensitivity knob on the back of the unit to make the unit more or less sensitive in Sound-Active mode. Turning the knob counterclockwise decreases the sensitivity; turning the knob clockwise increases the sensitivity.

### Master/Slave Mode (Master Sound, Master Auto):

This mode will allow you to link up to 32 units together without a controller. In this mode, the first unit in the daisy chain will automatically command all other units following.

1. Connect all LEDsplash™ 152B units in a daisy chain fashion as described in the section following.
2. Dipswitch settings on slave fixtures are not required and will have no effect.
3. Set all dipswitches on the Master unit to the "Off" position and the unit will run its built in color change program.

#### OPTIONS

- Set Music/Auto switch to Music and for sound-activated triggering of the program
- Set Music/Auto switch to Auto then use the rotary dial to adjust speed of the program
- See below under **DIP switch Options** for additional program settings

### Dipswitch Functions

FUNCTIONS	DIP SWITCHES ( ON )	NOTES & DESCRIPTION
Color change program (Auto/Music)	None	Music/Auto switch Music: Sound-Activated, sound adjustment knob sets sensitivity Auto: sound adjustment knob sets speed of program
Red LEDs	1	Low Intensity
	2	Medium Intensity
	3	Full Intensity
Green LEDs	4	Low Intensity
	5	Medium Intensity
	6	Full Intensity
Blue LEDs	7	Low Intensity
	8	Medium Intensity
	9	Full Intensity

# DMX Mode

A working DMX-512 signal source plugged into the LEDsplash™ 152B activates the DMX mode.

## DMX Channel Values

**NOTE!**

Please read all instructions carefully on fixture DMX control mode and addressing.

DMX channels 2, 3, 4, 5 and 6 functions are determined by the current settings of channel 1. For example, while Channel 1 is set between 000 and 029 the following conditions will apply;

- Channel 2 will control the Red LEDs
- Channel 3 will control the Green LEDs
- Channel 4 will control the Blue LEDs
- Channel 5 will control Strobing
- Channel 6 will control the Dimmer

CHANNEL	VALUE	FUNCTION	CH 2	CH 3	CH 4	CH 5	CH 6
1	000 ⇔ 029	<b>RGB Control Mode</b>	<b>Red</b> 000 ⇔ 255	<b>Green</b> 000 ⇔ 255	<b>Blue</b> 000 ⇔ 255	<b>Strobe</b> 000 ⇔ 020 No Strobe 021 ⇔ 255 Slow⇒Fast	
	030 ⇔ 059 060 ⇔ 089 090 ⇔ 119	<b>Pulse Strobe</b> Pulse ( 0 <-> 100% ) Pulse ( 100 <-> 0% ) Pulse ( 100 <->0% <->100)	<b>No Function</b>			<b>Speed</b> 000 ⇔ 255	
	120 ⇔ 149	<b>Color Macro</b> Color Macros	See Table 1.1			<b>No Function</b>	<b>Dimmer</b> 000 ⇔ 255
	150 ⇔ 179	<b>R,G,B Chase</b> RGB Chase pattern		<b>No Function</b>	<b>No Function</b>		
	180 ⇔ 209	<b>Automatic</b> Color Change	<b>No Function</b>			<b>Speed</b> 000 ⇔ 255	
	210 ⇔ 239	<b>Automatic (Fade)</b> Color Change w fade					
	240 ⇔ 255	<b>Sound Activated</b> Music/Auto switch must be set to Music				<b>No Function</b>	

**Table 1.1**

MODE	CH 2	DESCRIPTION
<b>Color Macro</b>  <b>Ch 1</b> <b>120 ⇔ 149</b>	000 ⇔ 016	<b>Red</b>
	017 ⇔ 056	Red ( Full ) Green: ( 0% ~ 100% )
	057 ⇔ 094	Green ( Full ) Red: ( 100% ~ 0% )
	095 ⇔ 096	<b>Green</b>
	097 ⇔ 136	Green ( Full ) Blue: ( 0% ~ 100% )
	137 ⇔ 174	Blue ( Full ) Green: ( 100% ~ 0% )
	175 ⇔ 176	<b>Blue</b>
	177 ⇔ 216	Blue ( Full ) Red: ( 0% ~ 100% )
	217 ⇔ 255	Blue ( Full ) Red ( Full ) Green: ( 0% ~ 100% )

**Music/Auto Switch**

**Note!** Regardless of DMX controller operated use, when the LED-PAR152B is set to run in Sound Active mode, you should make sure that all units are properly switched to Music and that you have adjusted the rotary dial to optimize the sound level response of the unit.

SWITCH	ROTARY FUNCTION
<b>AUTO</b>	Adjusts speed of built in program
<b>MUSIC</b>	Adjusts sound sensitivity of built in Mic.

## SETTING THE DMX STARTING ADDRESS

This DMX mode enables the use of a universal DMX controller device. Each fixture requires a "start address" from 1 to 512. A fixture requiring one or more channels for control begins to read the data on the channel indicated by the start address. For example, a fixture that uses 6 DMX channels and was addressed to start on DMX channel 100, would read data from channels: 100, 101, 102, 103, 104, and 105. Choose start addresses so that the channels used do not overlap, and note the start address selected for future reference.

If this is your first time addressing a fixture using the DMX-512 control protocol, we suggest jumping to the Appendix Section and reading the heading "DMX Primer". It contains very useful information that will help you understand its use.

Set the start address using the group of DIP switches located usually on bottom of the fixture. Each dip switch has an associated value. Adding the value of each switch in the ON position will provide the start address. Figuring out which switches to toggle ON given a specific start address can be accomplished by determining which switch values will add up to the address value, and turning these switches on. Do so by doing the following:

- 1) Determine the largest value switch that is less than the start address. Turn this switch on.
- 2) Subtract the value of the switch you just turned on from the starting address number.
- 3) Determine the largest value switch that is less than the remainder from the previous subtraction. Turn this switch on.
- 4) Subtract the value of the switch you just turned on from the remainder of the previous subtraction.
- 5) Repeat steps three and four until you have a remainder of zero.

### EXAMPLE STARTING ADDRESS

<p><b>Address 10</b></p> <p>Switch # 4 = 8 Switch # 2 = 2 Total = 10</p>	<p>256 128 64 32 16 8 4 2 1</p> <p>9 8 7 6 5 4 3 2 1</p> <p>ON OFF</p>																				
<p><b>Address 24</b></p> <p>Switch # 5 = 16 Switch # 4 = 8 Total = 24</p>	<p>256 128 64 32 16 8 4 2 1</p> <p>9 8 7 6 5 4 3 2 1</p> <p>ON OFF</p>																				
<p><b>Resolving address using simple math.</b></p> <p><b>Address 233</b></p>	<p>233 - (128) = 105, Turn ON Dip # 8 105 - (64) = 41, Turn ON Dip # 7 41 - (32) = 9, Turn ON Dip # 6 9 - (8) = 1, Turn ON Dip # 4 1 - (1) = 0, Turn ON Dip # 1</p> <table border="1" style="margin-left: auto; margin-right: auto;"> <thead> <tr> <th>DIPSWITCH</th> <th>(DMX VALUE)</th> </tr> </thead> <tbody> <tr><td>1</td><td>1</td></tr> <tr><td>2</td><td>2</td></tr> <tr><td>3</td><td>4</td></tr> <tr><td>4</td><td>8</td></tr> <tr><td>5</td><td>16</td></tr> <tr><td>6</td><td>32</td></tr> <tr><td>7</td><td>64</td></tr> <tr><td>8</td><td>128</td></tr> <tr><td>9</td><td>256</td></tr> </tbody> </table>	DIPSWITCH	(DMX VALUE)	1	1	2	2	3	4	4	8	5	16	6	32	7	64	8	128	9	256
DIPSWITCH	(DMX VALUE)																				
1	1																				
2	2																				
3	4																				
4	8																				
5	16																				
6	32																				
7	64																				
8	128																				
9	256																				

**DMX QUICK REFERENCE CHART**

**DMX Address Quick Reference Chart**

Dip Switch Position

DMX DIP SWITCH SET 0=OFF 1=ON X=OFF or ON					#9	0	0	0	0	0	0	0	0	1	1	1	1	1	1	1	1
					#8	0	0	0	0	1	1	1	1	0	0	0	0	1	1	1	1
					#7	0	0	1	1	0	0	1	1	0	0	1	1	0	0	1	1
					#6	0	1	0	1	0	1	0	1	0	1	0	1	0	1	0	1
#1	#2	#3	#4	#5																	
0	0	0	0	0		32	64	96	128	160	192	224	256	288	320	352	384	416	448	480	
1	0	0	0	0	1	33	65	97	129	161	193	225	257	289	321	353	385	417	449	481	
0	1	0	0	0	2	34	66	98	130	162	194	226	258	290	322	354	386	418	450	482	
1	1	0	0	0	3	35	67	99	131	163	195	227	259	291	323	355	387	419	451	483	
0	0	1	0	0	4	36	68	100	132	164	196	228	260	292	324	356	388	420	452	484	
1	0	1	0	0	5	37	69	101	133	165	197	229	261	293	325	357	389	421	453	485	
0	1	1	0	0	6	38	70	102	134	166	198	230	262	294	326	358	390	422	454	486	
1	1	1	0	0	7	39	71	103	135	167	199	231	263	295	327	359	391	423	455	487	
0	0	0	1	0	8	40	72	104	136	168	200	232	264	296	328	360	392	424	456	488	
1	0	0	1	0	9	41	73	105	137	169	201	233	265	297	329	361	393	425	457	489	
0	1	0	1	0	10	42	74	106	138	170	202	234	266	298	330	362	394	426	458	490	
1	1	0	1	0	11	43	75	107	139	171	203	235	267	299	331	363	395	427	459	491	
0	0	1	1	0	12	44	76	108	140	172	204	236	268	300	332	364	396	428	460	492	
1	0	1	1	0	13	45	77	109	141	173	205	237	269	301	333	365	397	429	461	493	
0	1	1	1	0	14	46	78	110	142	174	206	238	270	302	334	366	398	430	462	494	
1	1	1	1	0	15	47	79	111	143	175	207	239	271	303	335	367	399	431	463	495	
0	0	0	0	1	16	48	80	112	144	176	208	240	272	304	336	368	400	432	464	496	
1	0	0	0	1	17	49	81	113	145	177	209	241	273	305	337	369	401	433	465	497	
0	1	0	0	1	18	50	82	114	146	178	210	242	274	306	338	370	402	434	466	498	
1	1	0	0	1	19	51	83	115	147	179	211	243	275	307	339	371	403	435	467	499	
0	0	1	0	1	20	52	84	116	148	180	212	244	276	308	340	372	404	436	468	500	
1	0	1	0	1	21	53	85	117	149	181	213	245	277	309	341	373	405	437	469	501	
0	1	1	0	1	22	54	86	118	150	182	214	246	278	310	342	374	406	438	470	502	
1	1	1	0	1	23	55	87	119	151	183	215	247	279	311	343	375	407	439	471	503	
0	0	0	1	1	24	56	88	120	152	184	216	248	280	312	344	376	408	440	472	504	
1	0	0	1	1	25	57	89	121	153	185	217	249	281	313	345	377	409	441	473	505	
0	1	0	1	1	26	58	90	122	154	186	218	250	282	314	346	378	410	442	474	506	
1	1	0	1	1	27	59	91	123	155	187	219	251	283	315	347	379	411	443	475	507	
0	0	1	1	1	28	60	92	124	156	188	220	252	284	316	348	380	412	444	476	508	
1	0	1	1	1	29	61	93	125	157	189	221	253	285	317	349	381	413	445	477	509	
0	1	1	1	1	30	62	94	126	158	190	222	254	286	318	350	382	414	446	478	510	
1	1	1	1	1	31	63	95	127	159	191	223	255	287	319	351	383	415	447	479	511	

Dip Switch Position

DMX Address

## General Troubleshooting

Symptom	Solution(s)	Applies to			
		Lights	Foggers & Snow	Controllers	Dimmers & Chaser
Auto shut off	Check fan thermal switch reset	✓			
Beam is very dim or not bright	Clean optical system or replace lamp Check 220/110v switch for proper setting	✓			
Breaker/Fuse keeps blowing	Check total load placed on device				✓
Chase is too slow	Check users manual for speed adjustment	✓		✓	✓
Device has no power	Check for power on Mains. Check device's fuse. (internal and/or external)	✓		✓	✓
Fixture is not responding	Check DMX Dip switch settings for correct addressing Check DMX cables Check polarity switch settings	✓			
Fixture is on but there is no movement to the audio	Make sure you have the correct audio mode on the control switches. If audio provided via ¼" jack, make sure a live audio signal exists Adjust sound sensitivity knob	✓		✓	✓
Lamps cuts off sporadically	Possible bad lamp or fixture is overheating. Lamp may be at end of its life.	✓			
Light will not come on after power failure	Some discharge lamps require a cooling off period before the electronics in the fixture can kick start it again, wait 5 to 10 minutes before powering up	✓			
Loss of signal	Use only DMX cables Install terminator Note: Keep DMX cables separated from power cables or black lights.	✓	✓	✓	✓
Moves slow	Check 220/110v switch for proper setting	✓			
No flash	Re-install bulb, may have shifted in shipping	✓			
No laser output	Bounce mirror motor may have shifted during shipping, readjust	✓			
No light output	Check slip ring & brushes for contact Install bulb Call service technician	✓			
Relay will not work	Check reset switch Check cable connections				✓
Remote does not work	Make sure connector is firmly connected to device	✓	✓		
Stand alone mode	All Chauvet lighting fixtures featuring stand-alone functions do not require additional settings, simply power the fixture and it will automatically enter into this mode	✓			

**If you still have a problem after trying the above solutions, please contact CHAUVET Technical Support at the location on the next page.**

## Technical Support

Address: Service Dept.  
3000 N 29th Ct, Hollywood, FL 33020 (U.S.A.)  
Support (Email): [tech@chauvetlighting.com](mailto:tech@chauvetlighting.com)  
Telephone: (954) 929-1115 - (Press 4)  
Fax: (954) 929-5560 - (Attention: Service)  
Website: <http://www.chauvetlighting.com>

# 5. APPENDIX

## DMX Primer

There are 512 channels in a DMX-512 connection. Channels may be assigned in any manner. A fixture capable of receiving DMX 512 will require one or a number of sequential channels. The user must assign a starting address on the fixture that indicates the first channel reserved in the controller. There are many different types of DMX controllable fixtures and they all may vary in the total number of channels required. Choosing a start address should be planned in advance. Channels should never overlap. If they do, this will result in erratic operation of the fixtures whose starting address is set incorrectly. You can however, control multiple fixtures of the same type using the same starting address as long as the intended result is that of unison movement or operation. In other words, the fixtures will be slaved together and all respond exactly the same.

DMX fixtures are designed to receive data through a serial Daisy Chain. A Daisy Chain connection is where the DATA OUT of one fixture connects to the DATA IN of the next fixture. The order in which the fixtures are connected is not important and has no effect on how a controller communicates to each fixture. Use an order that provides for the easiest and most direct cabling. Connect fixtures using shielded two conductor twisted pair cable with three pin XLR male to female connectors. The shield connection is pin 1, while pin 2 is Data Negative (S-) and pin 3 is Data positive (S+). CHAUVET carries 3-pin XLR DMX compliant cables, DMX-10 (33'), DMX-4.5 (15') and DMX-1.5 (5')

## General Maintenance

To maintain optimum performance and minimize wear fixtures should be cleaned frequently. Usage and environment are contributing factors in determining frequency. As a general rule, fixtures should be cleaned at least twice a month. Dust build up reduces light output performance and can cause overheating. This can lead to reduced lamp life and increased mechanical wear. Be sure to power off fixture before conducting maintenance.

Unplug fixture from power. Use a vacuum or air compressor and a soft brush to remove dust collected on external vents and internal components. Clean all glass when the fixture is cold with a mild solution of glass cleaner or Isopropyl Alcohol and a soft lint free cotton cloth or lens tissue. Apply solution to the cloth or tissue and drag dirt and grime to the outside of the lens. Gently polish optical surfaces until they are free of haze and lint.

The cleaning of internal and external optical lenses and/or mirrors must be carried out periodically to optimize light output. Cleaning frequency depends on the environment in which the fixture operates: damp, smoky or particularly dirty surrounding can cause greater accumulation of dirt on the unit's optics. Clean with soft cloth using normal glass cleaning fluid. - Always dry the parts carefully. - Clean the external optics at least every 20 days. Clean the internal optics at least every 30/60 days.

## Returns Procedure

Returned merchandise must be sent prepaid and in the original packing, call tags will not be issued. Package must be clearly labeled with a Return Merchandise Authorization Number (RMA #). Products returned without an RMA # will be refused. Call CHAUVET® and request RA # prior to shipping the fixture. Be prepared to provide the model number, serial number and a brief description of the cause for the return. Be sure to properly pack fixture, any shipping damage resulting from inadequate packaging is the customer's responsibility. CHAUVET® reserves the right to use its own discretion to repair or replace product(s). As a suggestion, proper UPS packing or double-boxing is always a safe method to use.

**Note:** If you are given an RMA #, please include the following information on a piece of paper inside the box:

- 1) Your name
- 2) Your address
- 3) Your phone number
- 4) The RMA #
- 5) A brief description of the symptoms

## Claims

Damage incurred in shipping is the responsibility of the shipper; therefore the damage must be reported to the carrier upon receipt of merchandise. It is the customer's responsibility to notify and submit claims with the shipper in the event that a fixture is damaged due to shipping. Any other claim for items such as missing component/part, damage not related to shipping, and concealed damage, must be made within seven (7) days of receiving merchandise.

# Technical Specifications

## WEIGHT & DIMENSIONS

Length..... 5.1 in (129 mm)  
Width..... 7.5 in (191 mm)  
Height..... 8.1 in (207 mm)  
Weight..... 2.8 lbs (1.3 kg)

## POWER

Switch-selectable power settings..... 120 VAC, 60 Hz or 230 VAC, 50 Hz  
Fuse..... F 1.6 A, 250 V  
Power Consumption..... 20 W, 0.1A max @ 120 V  
Inrush Current..... 0.8 A @ 120 V

## LIGHT SOURCE

LED..... 151 (51 Red, 50 Green, 50 Blue) 100,000 hrs

## PHOTO OPTIC

Luminance @ 1m..... 740 lux  
Beam Angle..... 37°  
Field Angle..... 60°

## SATELLITE OPERATION

Run time @ 100% output (full RGB) ..... 8 hrs  
Maximum Run Time (auto program or single color) ..... > 8 hrs  
Connection..... 4-pin DIN connector

## THERMAL

Maximum ambient temperature..... 104° F (40° C)

## CONTROL & PROGRAMMING

Data input ..... locking 3-pin XLR male socket  
Data output ..... locking 3-pin XLR female socket  
Data pin configuration ..... pin 1 shield, pin 2 (-), pin 3 (+)  
Protocols..... DMX-512 USITT  
DMX Channels..... 6

## ORDERING INFORMATION

LEDsplash™ 152B..... LEDSPASH152B

## WARRANTY INFORMATION

Warranty..... 2-year limited warranty

